

NC

ENGINEERING

RT 1.5 3W

TRACKED DUMPER



RT1.5 3W

TRACKED DUMPER

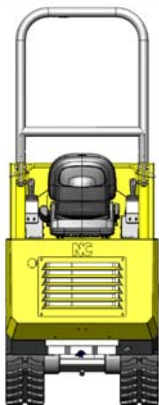
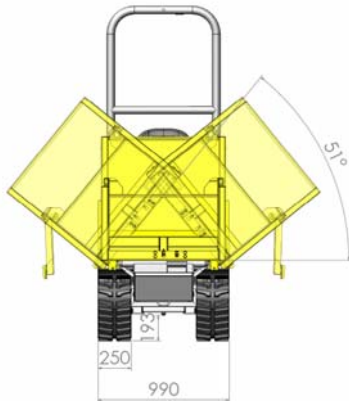
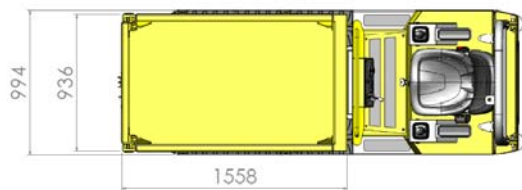
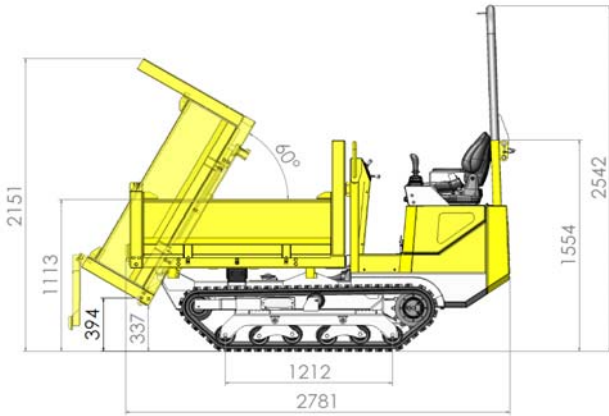

CAPACITY:

Max Safe Load	1500kg
Heaped	640L
Levelled	520L

ENGINE:

Make	Kubota
Model	D1105
Displacement	1123cc
Max power	17.5 KW @ 2600 rpm
Max Torque	72Nm @ 2000 rpm
Fuel	Diesel
Emissions	97/68/EG

TRANSMISSION:

Tandem variable displacement pumps driving two speed track motors
Max flow rate of 2 x 33L/min @ 250Bar

DRIVE CHARACTERISTICS:

Forward / Reverse	1st	0-3.2 km/h
	2nd	0-6.5 km/h
Turning Circle:	3.2m	
Grade-ability:	up to 70%	
Steering:	Hydrostatic skid steer	
Ground Pressure	0.26 / 0.51 kg/cm ²	
Park brake:	Electric Switch acting on hydrostatics	

Tracks:

250x56x72 FP Rubber tracks with hydraulic tensioning
Heavy duty fixed end rollers
Heavy duty sealed rollers in rocking bogies

TANK CAPACITIES:

Fuel:	20L
Hydraulic:	24L

SKIP:

Hydraulically operated 3 way tipping skip
Heavy duty fully welded skip with 5mm thick steel base plate
Automatic latches to release & lock doors during tipping and lowering
Removable posts, front and sides to make a flat platform

ELECTRICAL INSTALLATION:

Battery Type 075 Battery 550CCA 59Ah
Wiring harness in protective sleeving

WORKING HYDRAULICS:

Flow rate	22L/min
Working Pressure	170 bar

SEATING & CONTROLS

Seat accessible from both sides, clear access across dumper
Hand Throttle lever
Steering & Tipping by joysticks
Super bright warning lights on instrument display
Steel constructed centre console
Anti-slip floor

SERVICE ACCESS:

Easy access for service & maintenance
Hinged engine cover
Battery mounted securely under engine cover

OPTIONS:

Works lights kit



NC Engineering (Hamiltonsbawn) Ltd
2 Killyrudden Road, Hamiltonsbawn
Richhill, Co Armagh
Northern Ireland BT61 9SF

Tel: +44 (0) 28 3887 1970
Fax: +44 (0) 28 3887 0362